

CXL 1800-8C

8 dBd Omnidirectional Base Station Antenna for the 1800 MHz Band

PROCOM

DESCRIPTION:

- ★ Vertically polarised, omnidirectional base station antenna.
- ★ Approximately 8 dBd gain.
- ★ Provided with the heavy-duty type "C" mounting bracket – a universal fixation bracket made of epoxy-coated seawater resistant aluminium.
- ★ The accompanying U-bolts and fittings are made of stainless steel.
- ★ To be mounted on mast tubes, 27 to 65 mm in outer diameter.
- ★ The cable can be led either on the outside or along the inside of the mast tube.
- ★ Large bandwidth with respect to both SWR and gain.
- ★ Highly suitable for duplex operation with large spacing between the TX and the RX frequencies, e.g. the DCS-1800/PCN cellular system.
- ★ The antenna element is sealed in a high-quality, conical glassfiber tube.
- ★ All metal parts in the antenna are DC-grounded to reduce the noise caused by atmospherical discharge. Consequently, the antenna shows a DC-short across the coaxial cable.
- ★ The CXL 1800-8C is a vibration-proof, slim-line, corrosion resistant, modern style base station antenna.

SPECIFICATIONS:

ELECTRICAL	
MODEL	CXL 1800-8C
ANTENNA TYPE	Coaxial, colinear antenna, broad-banded
FREQUENCY	1710–1880 MHz
IMPEDANCE	Nom. 50 Ω
POLARISATION	Vertical
GAIN	10 dBi 8 dBd
BANDWIDTH	Approx. 200 MHz at SWR ≤ 1.75
SWR	≤ 1.75, typ. ≤ 1.5
MAX. POWER	100 watt
ANTISTATIC PROTECTION	All metal parts DC-grounded (Connector shows a DC-short)
MECHANICAL	
TEMP. RANGE	-30° C +70° C
CONNECTOR	N-female
WIND SURFACE	Approx. 0.04 m ²
WIND LOAD	Approx. 44 N (at 150 km/h)
COLOUR	Marine white
MOUNTING	Radome: Polyurethane coated fiberglass Mounting bracket: Seawater resistant aluminium, epoxy-coated
TOTAL HEIGHT	Approx. 1.5 m
WEIGHT	Approx. 1.5 kg
MOUNTING	On 27–65 mm dia. mast tube

MULTI-PURPOSE MOUNTING BRACKET:

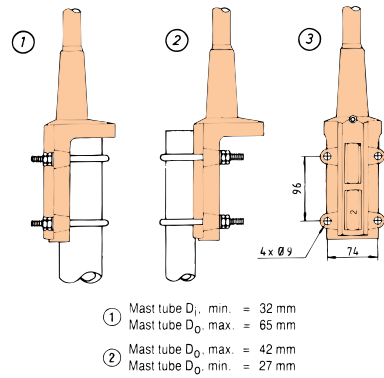

TYPICAL RADIATION PATTERN (E-PLANE)

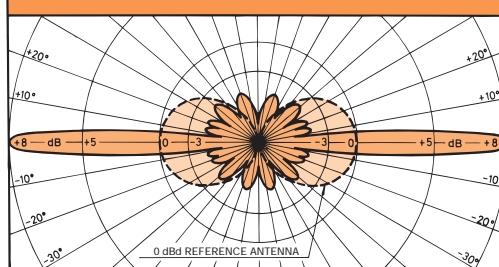

TYPICAL RADIATION PATTERN (H-PLANE)

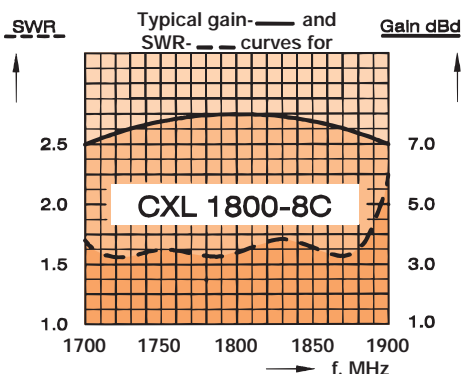
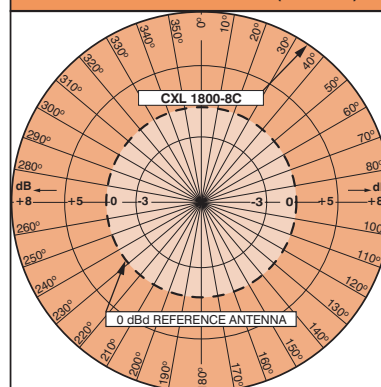

PLEASE NOTE:

The antenna is delivered with a DC-connection between the antenna element and the mounting bracket (i.e. the mast tube). This feature is important when the antenna is used as a base station antenna.

PROCOM A/S reserve the right to amend specifications without prior notice.